



VT Prusik
By Rich Carlson

7

The BlueWater VT Prusik was designed in conjunction with Rich Carlson. Originally designed for canyoneering, the VT Prusik has applications in other rope-related disciplines as well, including tree climbing, rock climbing, mountaineering, caving, rappelling and technical rescue.

A super tough and heat resistant Technora aramid sheath covers durable nylon core strands. Bar tacked with BlueWater's custom Technora thread for superior strength.



Dimensions

- Diameter: 7mm
- Length: 81cm (32 in)

Tensile Strengths

- End to end: 11.3 kN (2500 lbf)
- Basket config: 22.6 kN (5000 lbf)

For personal use on ropes 8 mm to 9.5 mm

Product #7568606

06/2017

WARNING

Any person using BlueWater equipment in any manner is personally responsible for learning the proper techniques involved, assumes all risks, and accepts full and complete responsibility for any and all damages or injury of any kind, including death, which may result from the use of any BlueWater equipment.

Performance will vary based on rope size, type and condition. Test and practice with your rope and other equipment in a safe manner to determine compatibility and performance characteristics before applying in the vertical realm.

Failure to follow all instructions in the proper use and care of this equipment can result in serious injury or death to the user and/or bystanders.

The VT Prusik can be used in so many ways that it is impossible to show them all. Experience in rigging and rappelling is required. The best way to gain specific training in uses of the VT Prusik is by attending a workshop. Visit totemrigging.com for usage and workshop information.

Manufactured by:
BlueWater Ropes

209 Lovvorn Road
Carrollton GA 30117
Tel: 770-834-7515
www.bluewaterropes.com

Also available from:
Canyons & Crags

Cedar City UT
Tel: 877-RAPPEL-8
www.canyonsandcrag.com

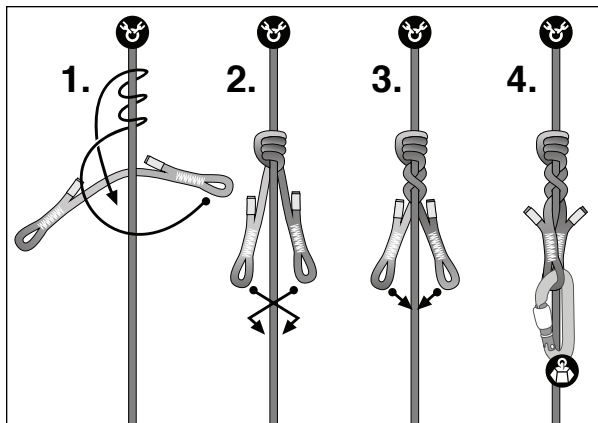

Valdotain Tresse (VT)

The VT is a friction hitch that can be used to ascend and descend fixed ropes. When tied properly, it can be released under load. Applications include self-belay on rappel, passing knots on rappel, as a load releasing hitch, for performing pick-offs on tensioned rope, etc.

1. Make 3-4 wraps around host rope.
2. Bring tails down so ends are even.
3. Cross strands in front and back of host rope.
4. Join eyes with carabiner.

NOTE: Number of wraps and crosses required for optimal performance will vary with rope size, type and condition.

WARNING: When used for self-belay on rappel it is recommended to rig the VT above the rappel device. Auto-blocks rigged below the rappel device may become jammed in the rappel device or may not lock when needed if distance between the autoblock and rappel device is not set properly.

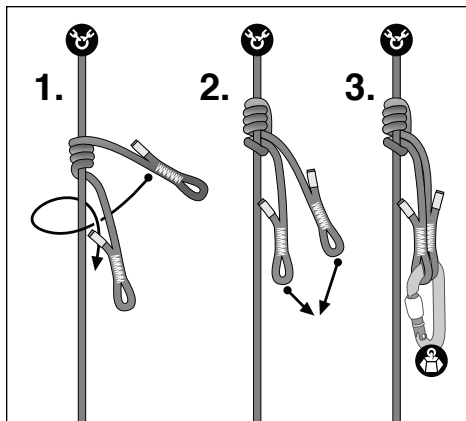

Asymmetric Prusiks

The Schwabisch (left) and the Distel (right) are asymmetric prusik hitches that can be used to ascend fixed ropes. They also work well with prusik-minding pulleys to create Progress Capture Devices (PCDs) in haul systems.

Both hitches have similar performance characteristics. Number of wraps should be adjusted to rope diameter.

